



RIFLE RANGE FACILITIES:

DESIGN REFERENCE FOR .22 CAL. AND BLACK POWDER RIFLE RANGE INCLUDING RANGE LAYOUT, LOCATION / ORIENTATION, LEAD RECOVERY, BULLET STOP CRITERIA AND PLANS FOR FIRING LINE SHELTER, SHOOTING BENCH, TARGET HOLDER, GUN RACK, BULLET DEFLECTOR / TRAP AND RICOCHET CATCHER.



ASSISTANCE OF THE NATIONAL RIFLE ASSOCIATION IS GRATEFULLY ACKNOWLEDGED



ENGINEERING SERVICE
IRVING TEXAS
972 580 7826

RIFLE RANGE

DECEMBER 2008

DESIGN
311
GUIDELINE

RANGE LAYOUT

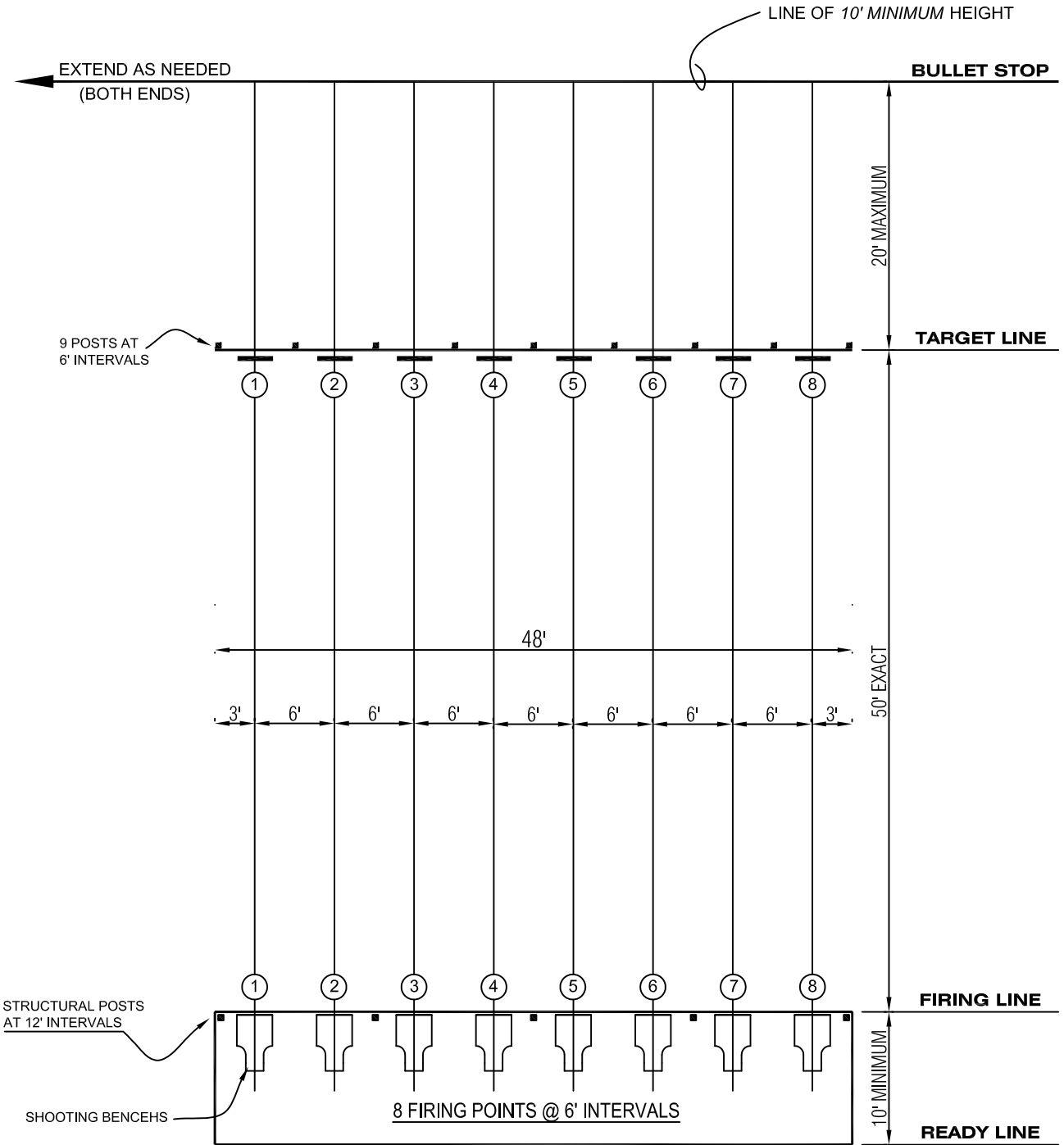

BEST ORIENTATION IS "NORTHERLY" TO MINIMIZE INTERFERENCE OF SUNLIGHT



RIFLE RANGE SHELTER AND EQUIPMENT

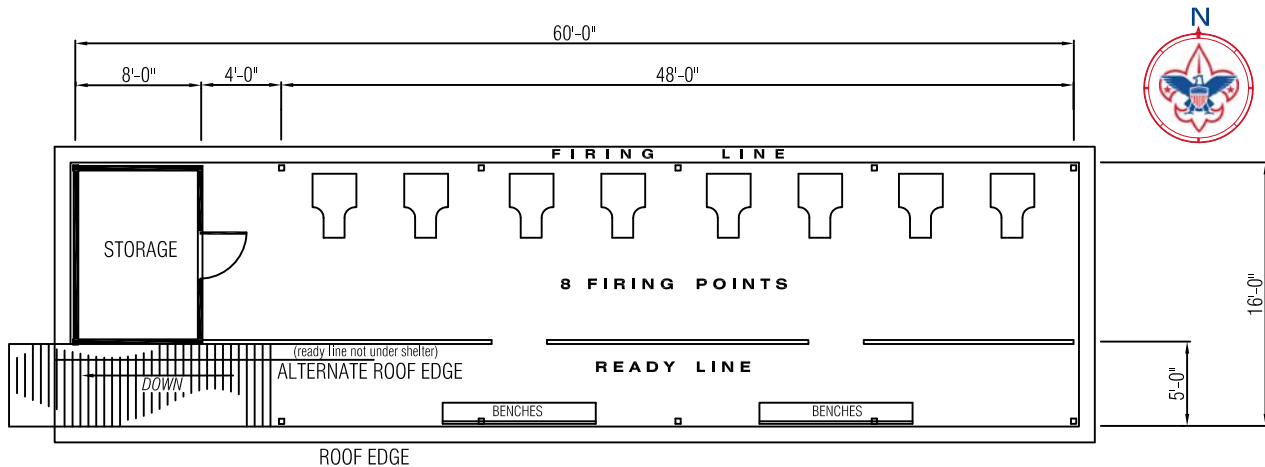

SHELTER REQUIREMENTS

- * 8 FIRING POSITIONS
- * CONCRETE SLAB OR WOOD DECK FLOOR.
- * SIMPLE, OPEN STRUCTURE WITH LOW EAVES AND ADEQUATE OVERHANG OF ROOF. PITCHED OR SHED ROOF DESIGN TO PROVIDE RUN-OFF. OVERHANG IMPORTANT ON SOUTH SIDE TO SHELTER THE READY LINE.
- * STORAGE LOCKER FOR EQUIPMENT AND SUPPLIES.
- * CONSIDER GUTTERING OR DRIP DIVERTERS, AS APPROPRIATE, PLUS CRUSHED ROCK UNDER THE DRIP LINE.

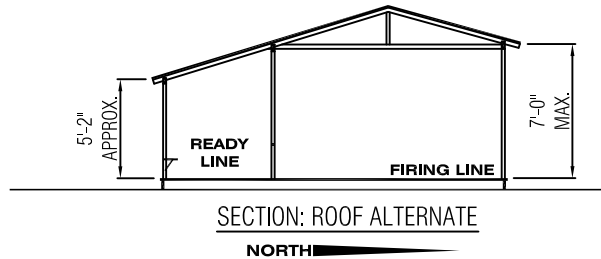

ALTERNATE SAFETY BAR CONSTRUCTION METHODS

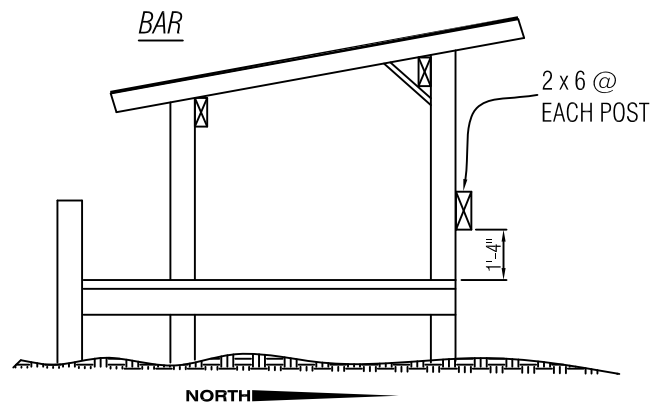
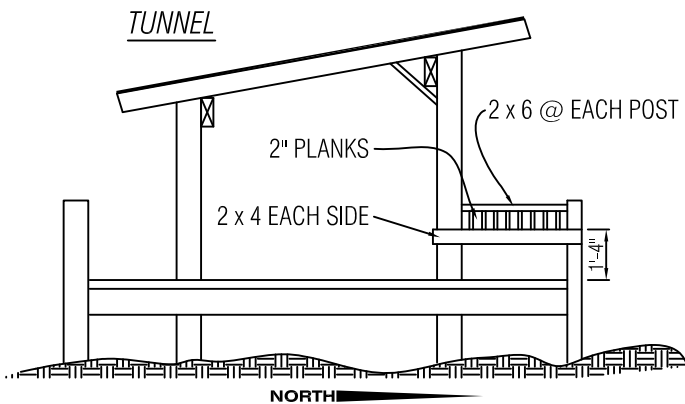

LOCATION / ORIENTATION

(THINK SAFETY)

1. IMMEDIATE IMPACT AREA IS FULLY CONTAINED WITHIN PROPERTY BOUNDARIES.
2. BEST ORIENTATION IS NORTH TO NORTHEAST, TO MINIMIZE SUNLIGHT INTERFERENCE.

IMPACT AREAS

(NOTE: ACTUAL CONFIGURATIONS WILL BE DETERMINED BY LOCAL CONDITIONS.)

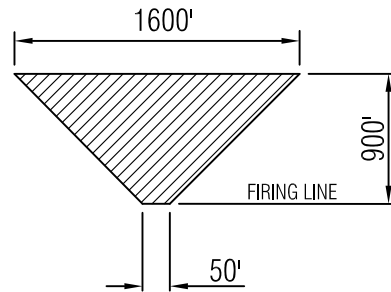

IMMEDIATE IMPACT AREA (ALL RANGES)

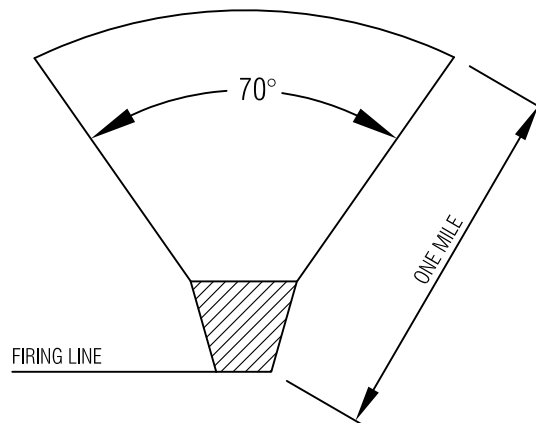

DISTANT IMPACT AREA (WITHOUT SIDE BERMS)

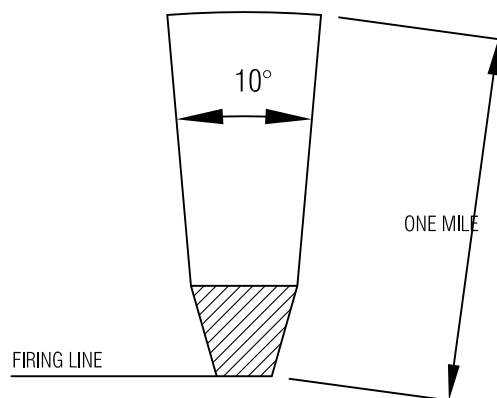

DISTANT IMPACT AREA (WITH SIDE BERMS)

FENCING

1. RANGE MUST BE ENCLOSED WITH A PHYSICAL BARRIER FENCE. THIS INCLUDES FIRING LINE, TARGET LINE, ENTIRE BULLET STOP AND ANY OTHER AREA CONTROLLED BY RANGEMASTER.
2. IMMEDIATE IMPACT AREA MUST BE MARKED AND / OR FLAGGED TO WARN OF DANGER.
3. ACTUAL DISTANT IMPACT AREA IS LOCALLY DETERMINED, AS ARE ITS SAFETY REQUIREMENTS.

LEAD RECOVERY

LEAD IS CLASSIFIED AS A **HAZARDOUS MATERIAL**. INTRODUCTION OF LEAD INTO THE ENVIRONMENT REQUIRES THAT THE COUNCIL DOCUMENTS A MANAGEMENT PLAN FOR SCHEDULED PERIODIC RECOVERY, REMOVAL AND DISPOSAL AT A LICENSED LOCATION.

RECOVERY USUALLY INVOLVES SIFTING THE SOIL AND ISOLATING LEAD. THIS CAN BE FACILITATED BY MEANS OF A CONSTRUCTED BULLET DEFLECTOR OR BY A COMMERCIALY MADE BULLET TRAP.

REFERENCES:

1. *ENVIRONMENTAL ASPECTS OF CONSTRUCTION AND MANAGEMENT OF OUTDOOR SHOOTING RANGES*, 1997 NATIONAL SHOOTING SPORTS FOUNDATION.
2. *LEAD MOBILITY AT SHOOTING RANGES*, 1996, SPORTING ARMS AND AMMUNITION MANUFACTURE'S INSTITUTE.
3. *THE RANGE MANUAL, A GUIDE TO PLANNING AND CONSTRUCTION*, 1989, THE NATIONAL RIFLE ASSOCIATION.

BULLET STOP CRITERIA

EARTH BERMS: USE ONLY HOMOGENEOUS SOIL, FREE OF ROCK OR OTHER MATERIAL LIKELY TO CAUSE RICOCHET.

BACKSTOP

BACKSTOP BERM: REQUIRED IF SLOPE OF GROUND SURFACE WITHIN 50' BEYOND TARGET LINE IS

- a. LESS THAN 35°, OR
- b. DOES NOT EXCEED 10 FEET IN HEIGHT ABOVE ELEVATION OF FIRING LINE.

SIDE BERM(S)

REQUIRED WHERE PEOPLE OR FACILITIES MAY BE ADJACENT TO THE RANGE WITHIN A 300 YARD RADIUS ARC OF 180°, FORWARD OF, AND CENTERED ON, THE FIRING LINE.

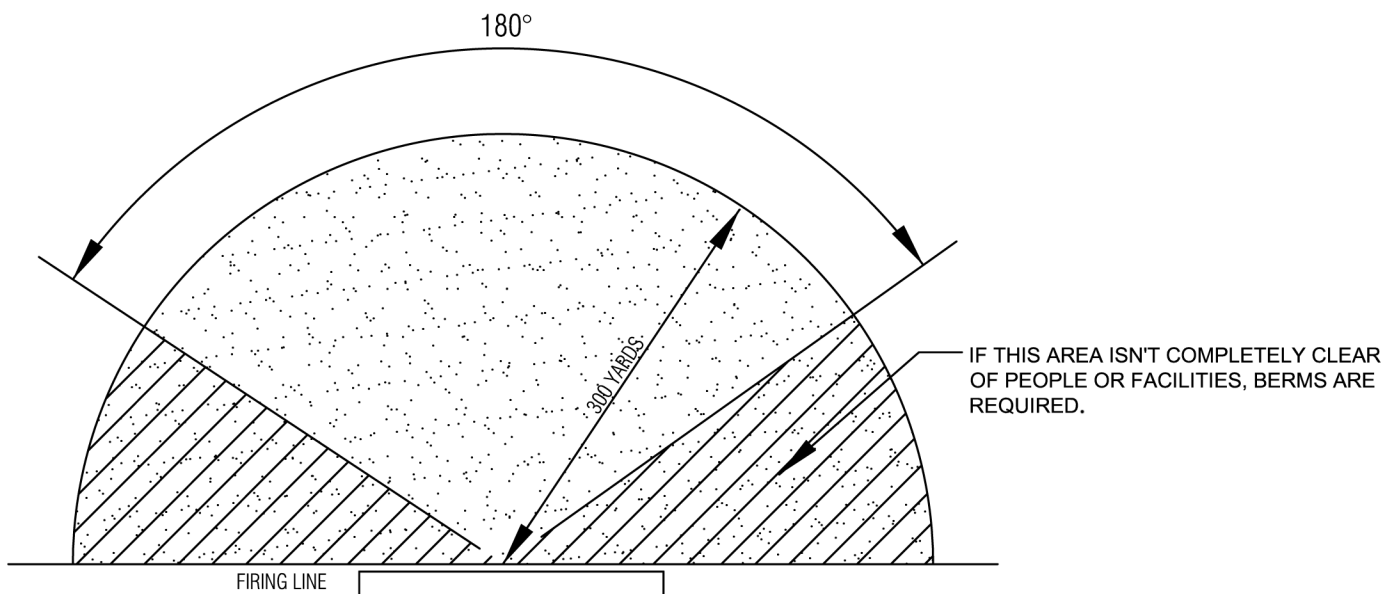

IMPORTANT NOTE:

THIS REFERENCE INFORMATION MAY BE INSUFFICIENT FOR LOCAL CONDITIONS, AND FINAL AUTHORITY FOR RANGE SAFETY RESIDES WITH RANGEMASTER.

EARTH BERM

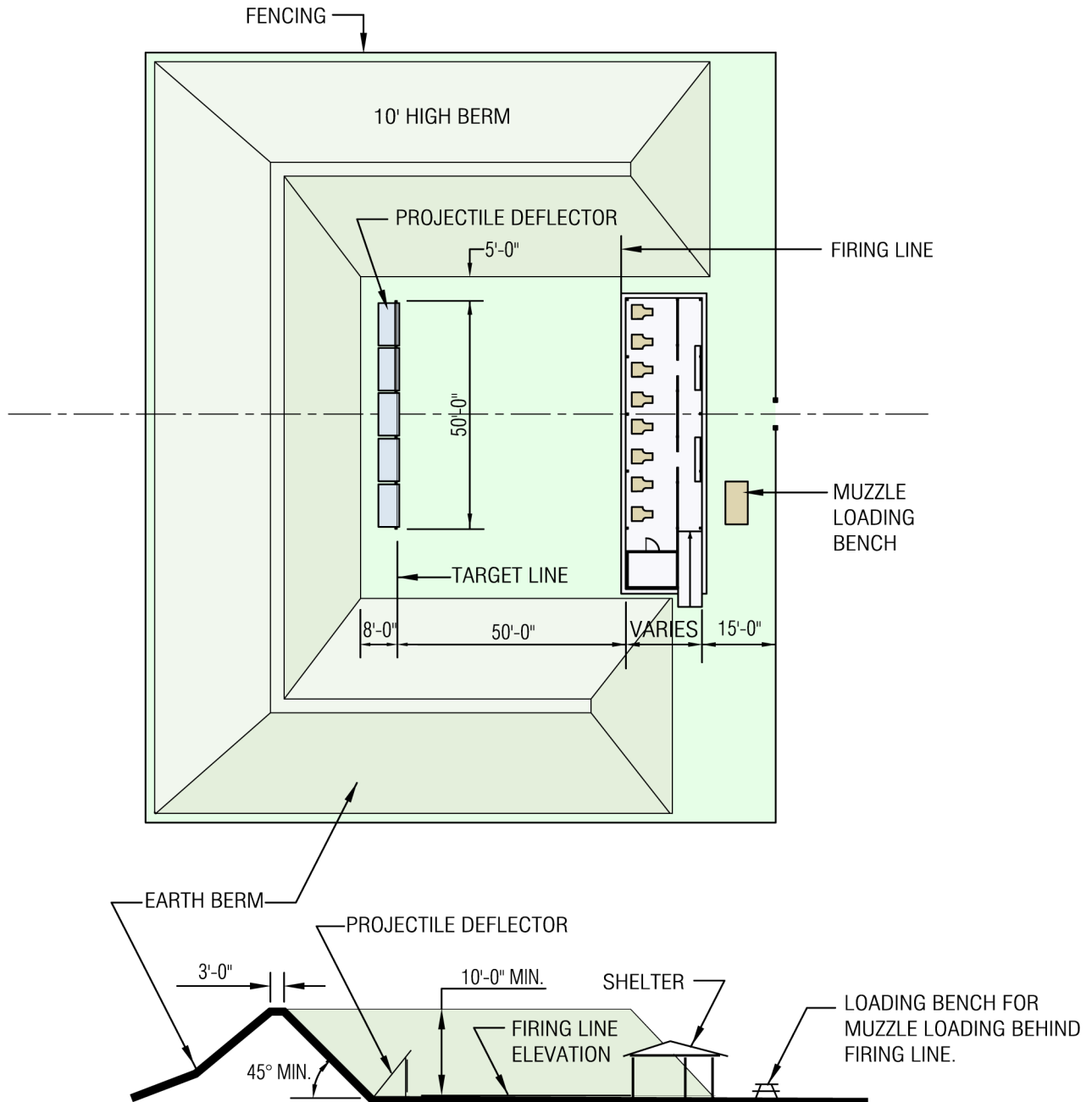

SIDE BERMS, TEN FEET IN HEIGHT, ARE REQUIRED ALONG THE RIGHT AND / OR LEFT SIDES OF THE RIFLE RANGE, CONNECTING THE BACKSTOP (BUILT-UP EARTH OR NATURAL HILLSIDE) TO THE FIRING LINE WHENEVER THERE ARE ROADS, BUILDINGS, CAMPSITES OR OTHER FACILITIES ADJACENT TO THE RANGE AND IN THE DIRECT LINE OF SIGHT WITHIN A 180 DEGREE ARC ALONG AND IN FRONT OF THE FIRING LINE.

NATURAL HILLSIDE OPTIONS

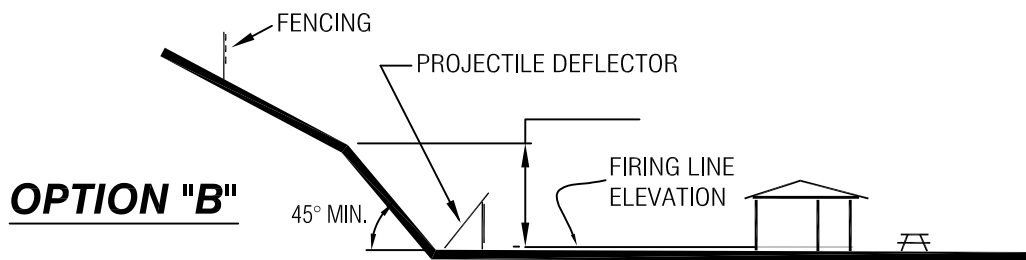
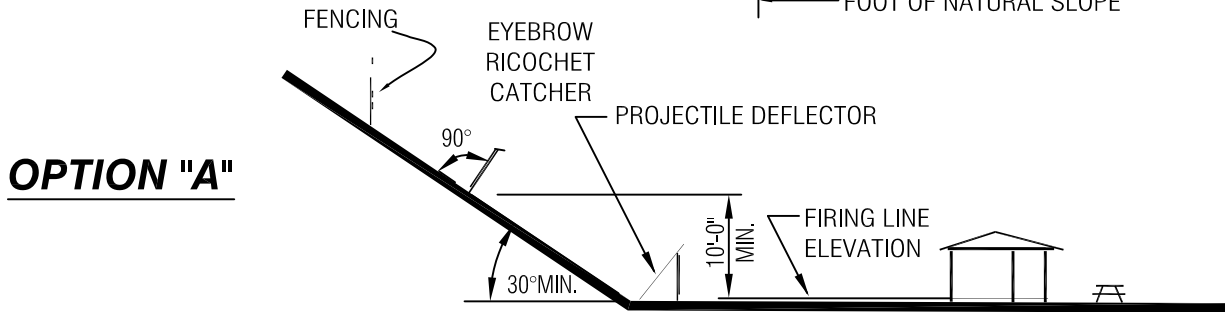
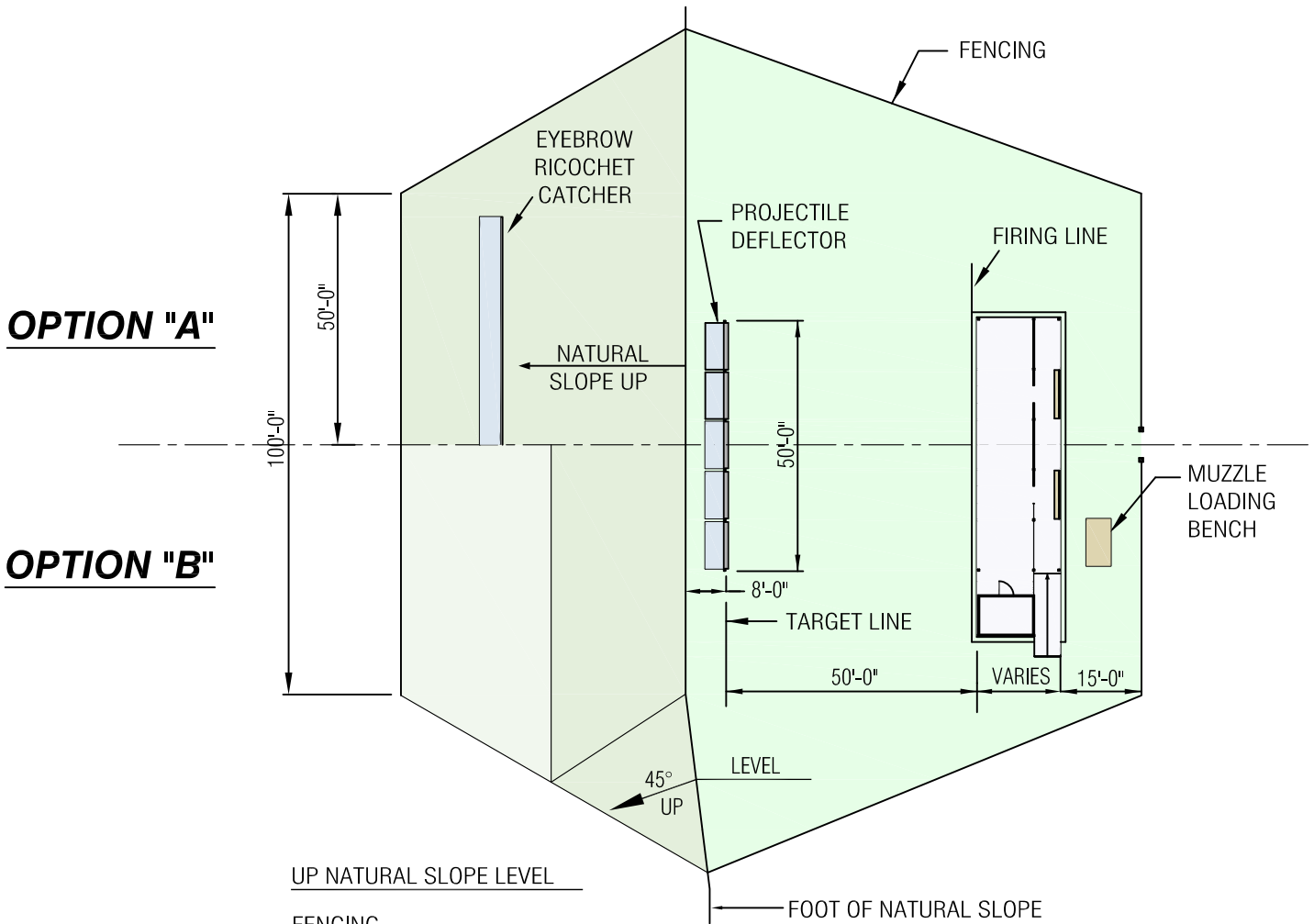

EYEBROW RICOCHET CATCHER

AN EYEBROW RICOCHET CATCHER IS NEEDED WHEN THE NATURAL OR CUT HILLSIDE IS LESS THAN 45 DEGREES, BUT GREATER THAN THE MINIMUM ACCEPTABLE ANGLE OF 35 DEGREES. USE PRESSURE-TREATED 4" x 4" POSTS AND 3/4" PLYWOOD OR NOMINAL 2" DIMENSION LUMBER. THE BOTTOM OF THE CATCHER MUST BE LOCATED 10' ABOVE THE FIRING LINE ELEVATION. INSTALL THE CATCHER AT 90 DEGREES TO THE SLOPE OF THE HILL.

RANGE LAYOUT (MULTIPLE DISTANCES)

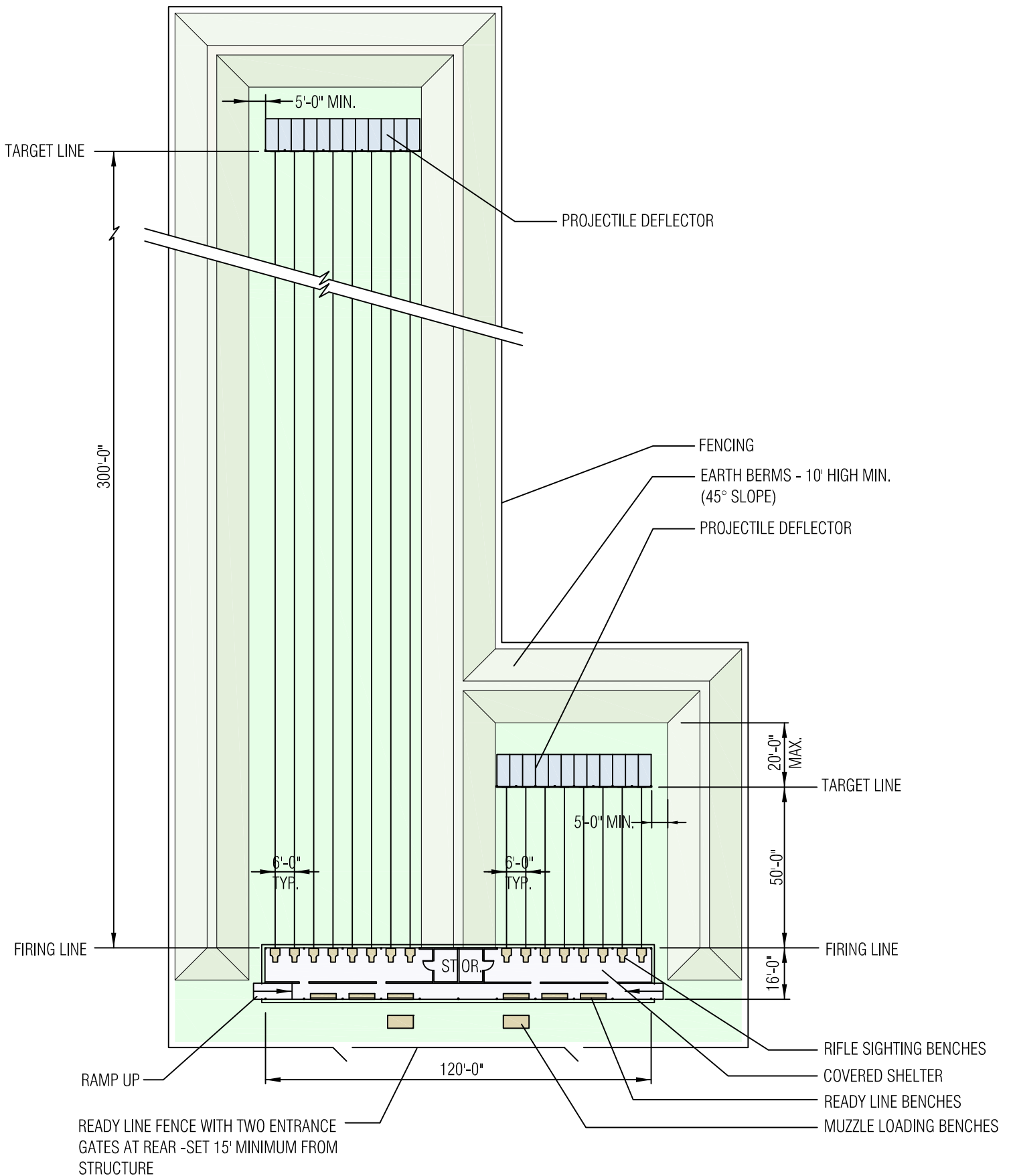

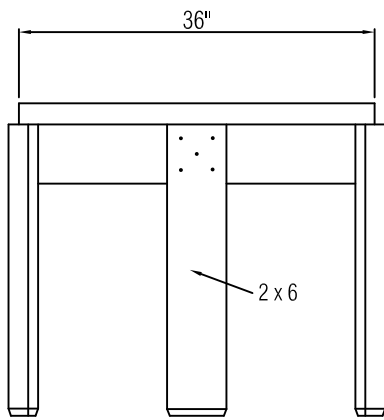

END VIEW

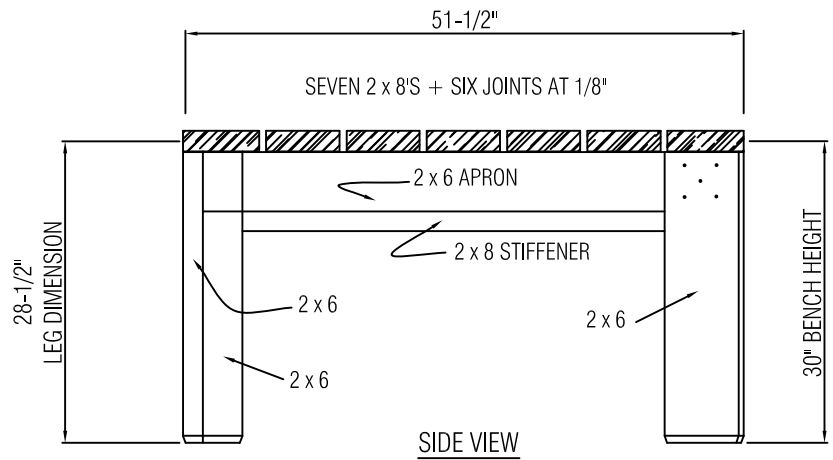

SIDE VIEW

* 30" BENCH HEIGHT IS FOR YOUTH USE WITH STANDARD (17") CHAIR OR STOOL
 * TRIPOD DESIGN IS STABLE ON IRREGULAR FLOOR

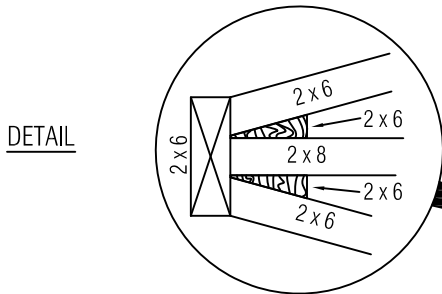

DETAIL

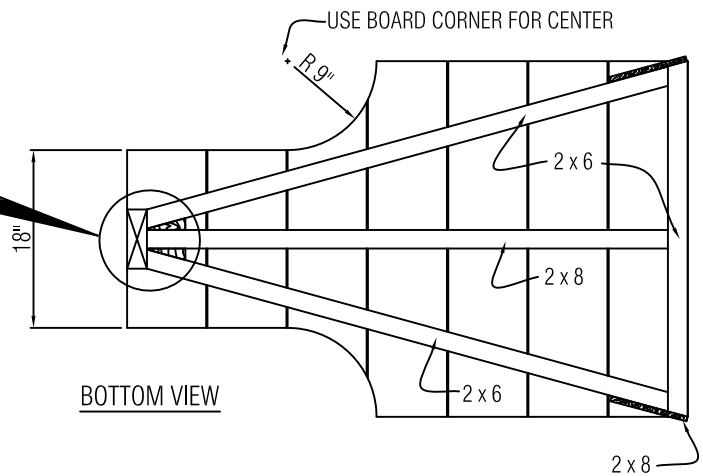

BOTTOM VIEW

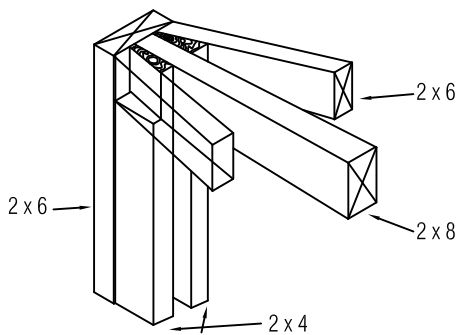

VIEW OF NOTCHED
LEG ASSEMBLY

RIFLE RANGE SIGHTING BENCH

- * CUT ANGLE 17°
- * IMPORTANT : GLUE AND NAIL ALL JOINTS.
- * FOR BEST RESULTS, USE CCA PRESSURE-TREATED LUMBER (WOLMANIZED OR EQUAL)
- * THANKS TO THE NATIONAL RIFLE ASSOCIATION, AND NORTH FLORIDA COUNCIL, #87, BSA

RIFLE RANGE EQUIPMENT

THE TARGET HOLDER IS AN ESSENTIAL PART OF THE RIFLE RANGE, AND THE PORTABLE GUN RACK HELPS WITH THE ISSUE AND CONTROL OF RIFLES.

TARGET HOLDER

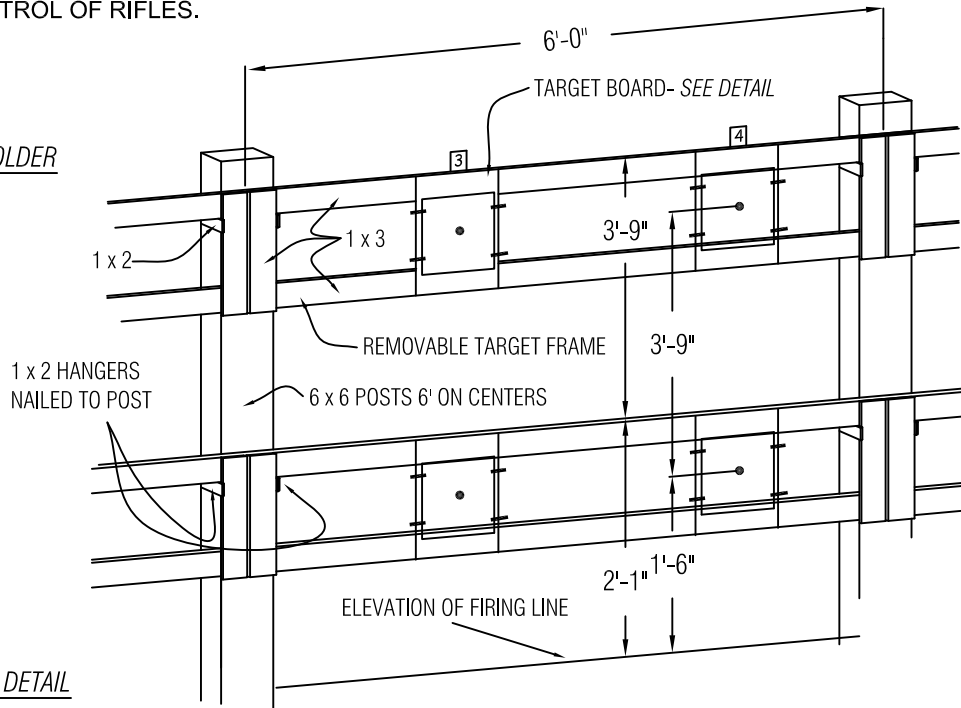

TARGET BOARD DETAIL

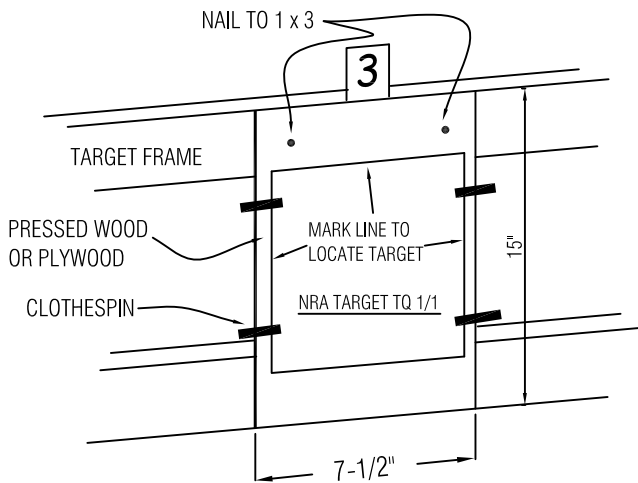

GUN RACK

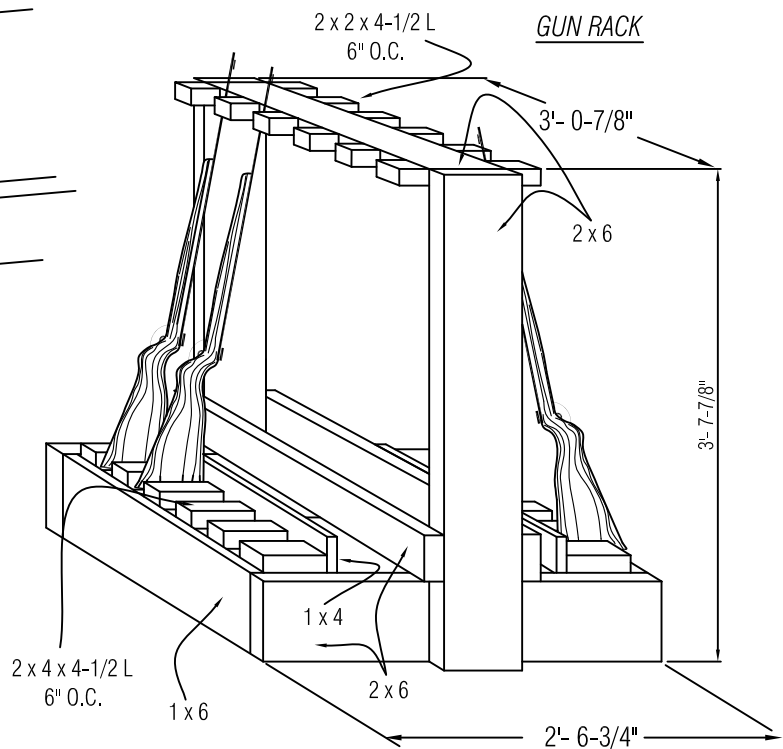

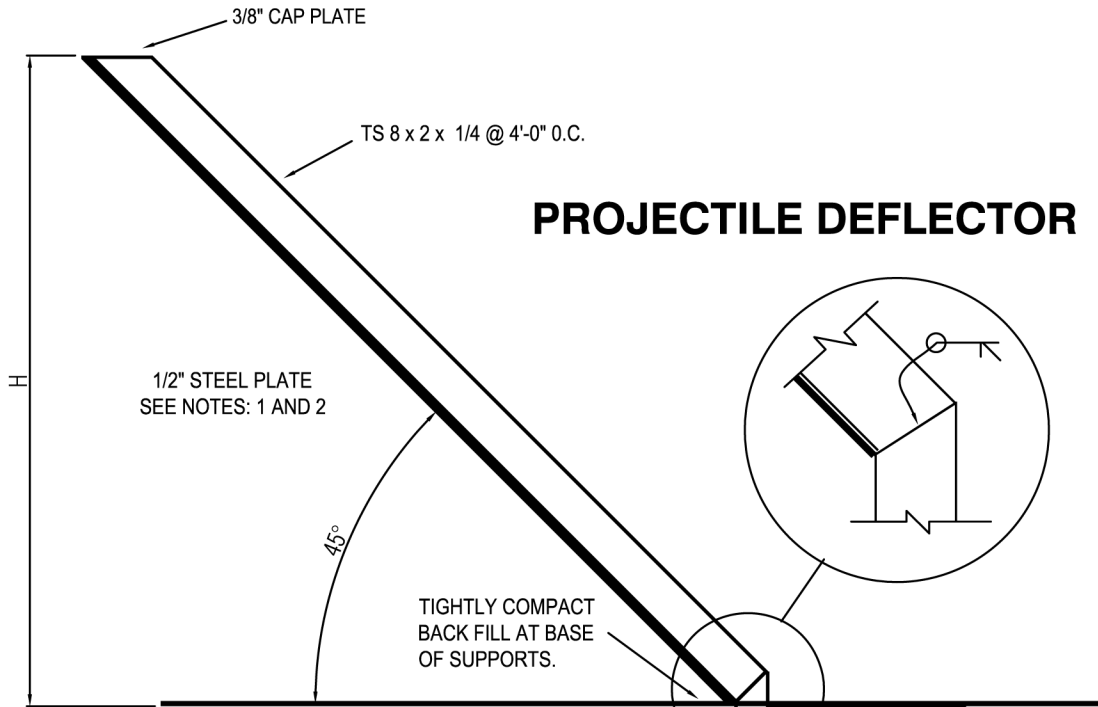

PROJECTILE DEFLECTOR

NOTES:

1. THE U.S. STEEL SPECIFICATION IS TYPE T1-A AND THE BETHLEHEM STEEL SPECIFICATION IS (RQC - 100 - A).

THESE ARE CHARACTERIZED BY THE FOLLOWING SPECIFICATIONS:

- * ASTM TYPE - A514, GRADE B
- * YIELD STRENGTH, MINIMUM - 100,000 PSI
- * TENSILE STRENGTH, MINIMUM - 115,000 TO 135,000 PSI
- * ELONGATION IN 2 IN. MINIMUM - 16 TO 18 PERCENT
- * REDUCTION OF AREA, MINIMUM - 35 TO 40 PERCENT
- * BRINNEL HARDNESS - 321

THIS TYPE OF STEEL IS HEAT TREATED AND REQUIRES LOW HYDROGEN WELDING PRACTICE IN ORDER TO AVOID IMPAIRING THE PERFORMANCE OF THE MATERIAL IN THE HEAT AFFECTED ZONE. LOW HEAT INPUTS ARE ALSO NECESSARY.

2. STEEL PLATES SHALL HAVE MILLED EDGES AT ALL JOINTS. JOINTS SHALL BE BUTTED FLUSH AND SMOOTH. PLATES SHALL BE FREE FROM BUCKLE OR WAVE AFTER ERECTION. EXPOSED EDGES SHALL BE BEVELED AT 45 DEGREES TO A FILLET APPROXIMATELY 1/16" THICK. THERE SHALL BE NO HORIZONTAL JOINTS IN ANY STEEL PLATE WORK. WELDING SHALL BE IN ACCORDANCE WITH THE AMERICAN WELDING SOCIETY CODE FOR WELDING IN BUILDING CONSTRUCTION.

STEEL PLATE SHALL BE SPOT WELDED TO STEEL SUPPORTS NOT MORE THAN 6 INCHES ON CENTER ALONG THE LENGTH OF SUPPORT.

3. PRIME AND PAINT ALL STEEL.
4. WHERE 2 PLATES ABUT, JOINTS SHALL OCCUR ON THE CENTER LINE OF THE SUPPORTING TUBE. OVERLAP PLATE ON TUBE AT END SO THAT NO PORTION OF THE TUBE IS EXPOSED TO THE LINE OF FIRE.
5. TUBE SIZE AND FOOTING ARE SIZED FOR MAXIMUM "H" OF 12'-0". IF "H" EXCEEDS 12'-0", TUBE SIZE AND FOOTING DEPTH SHALL INCREASE.

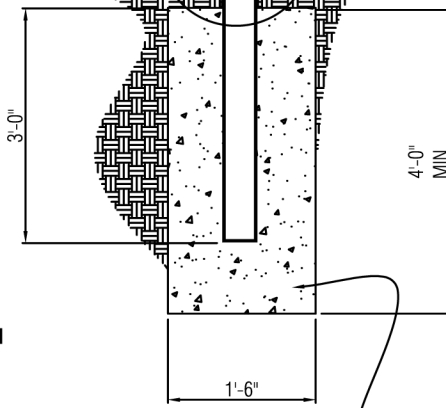

1'-6" Ø CONCRETE PIER. CONCRETE SHALL HAVE A MINIMUM COMPRESSIVE STRENGTH OF 3000 PSI